

6-Year Limited Warranty on Heat Exchanger, Tank and Parts*

The Hybrid water heater is the latest in cutting edge technology from American Water Heaters that combines the best attributes of conventional and tankless technology to provide the best of both worlds.

QUALIFIES FOR 2010 FEDERAL TAX CREDIT OF UP TO \$1,500

ENERGY EFFICIENCY

- Patented circulation system delivers 90% thermal efficiency, ensuring maximum heat transfer, saving money on operating costs compared to a standard 78% efficient conventional or 84% tankless gas water heaters.
- Condensing design includes condensate drain trap

HYBRID TECHNOLOGY

- Innovative technology that surpasses existing conventional and tankless designs
- Patented water flow circulation system provides the performance of a tankless unit with extremely quick recovery
- First hour delivery of 189 gallons of hot water
- Smaller than a conventional 50-gallon gas water heater, but with twice the hot water delivery
- Whole-home solution regardless of geography

IMPROVED HOT WATER DELIVERY

- Continuous hot water shower after shower when properly sized for your home
- No minimum flow rate for ignition
- No cold water sandwich
- Delivers hot water faster than tankless
- Internal storage easily handles peak demand

SOPHISTICATED ELECTRONICS

- User-friendly integrated temperature controller with LED numeric display allows for precise temperature settings
- Multiple Lifestyle Modes - Energy Saver, Vacation and Boost modes allow for simple one-touch customization based on specific hot water needs
- Safety lock feature deters unwanted access
- Error code display for easy troubleshooting

LOWER INSTALLATION COSTS

- Utilizes 1/2" gas line standard in most homes today
- Extremely low exhaust temperature enables PVC venting for easier, more economical installations
- Less expensive venting material versus stainless steel venting used with most tankless models
- Hot and cold water connections similar to conventional tank-style models

POWER VENT DESIGN

- Uses inexpensive PVC, CPVC or ABS pipe for venting
- Can be vented vertically thru-the-roof or horizontally thru-the-wall
- 2" pipe vents up to 50 equivalent feet
- 3" pipe vents up to 100 equivalent feet



GH-90N



ANSI Z21.10.3



CSA 4.3

*For complete warranty information consult the written warranty of American Water Heaters found at www.americanwaterheater.com, or call (800) 456-9805.



Residential Gas Hybrid Water Heater

MODEL	FIRST HOUR RATING GALLONS	RECOVERY 90°F RISE GALLONS	INPUT	MANIFOLD PRESSURE			ELECTRICAL CHARACTERISTICS		SHIPPING WEIGHT LBS/KGS
			BTU/HR	GAS TYPE	IN. WC	kPA	VOLTS/HZ	AMPERES	
GH-90N	189	121	100,000	NAT	4.2	1.05	120/60	2.5	198/90

This gas-fired water heater is design certified by CSA International under American National Standard/CSA Standard for Gas Water Heaters ANSI Z21.10.3 • CSA 4.3 (current edition).

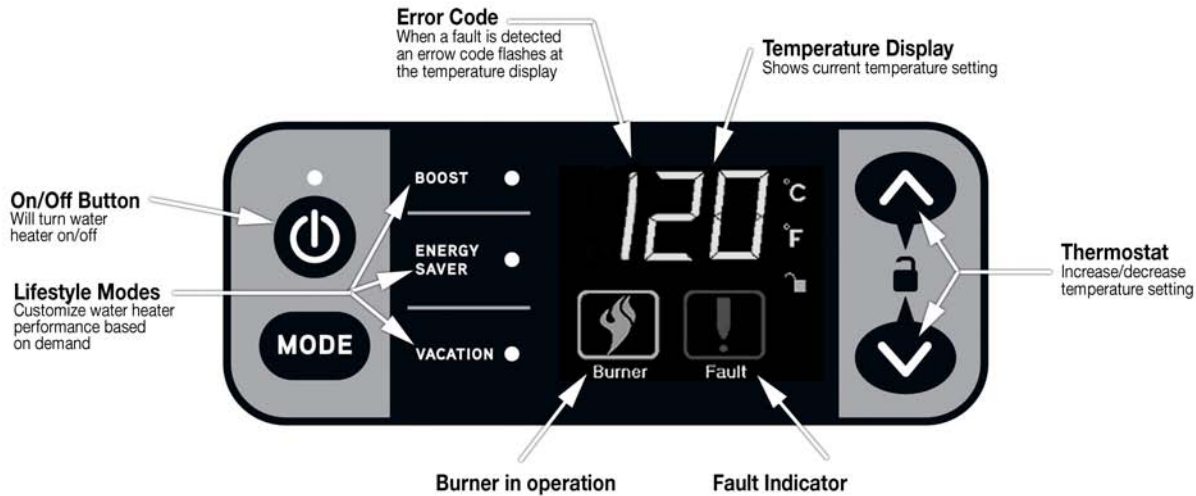
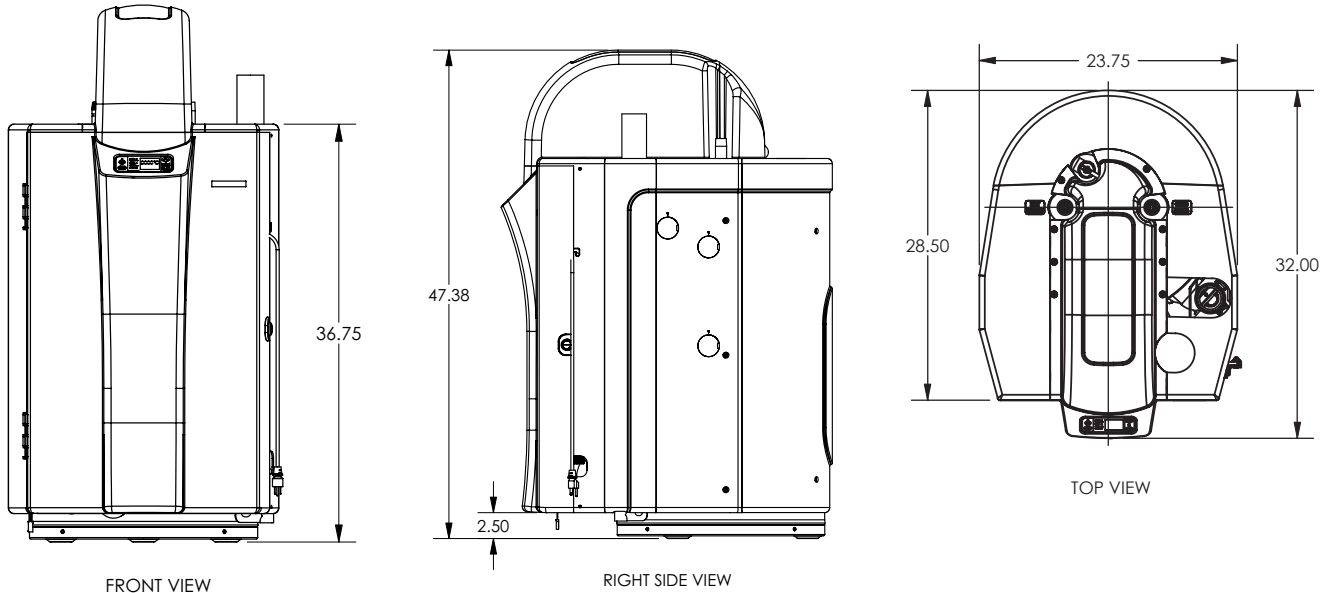

Distributed By:

Order Entry and Sales

500 Princeton Road (FEDEX, UPS)
Johnson City, TN 37601-2030
P.O. Box 4808 (Mailing)
Johnson City, TN 37602-4808
(800) 937-1037
FAX (800) 581-7224

Warranty and Service

500 Princeton Road (FEDEX, UPS)
Johnson City, TN 37601-2030
P.O. Box 1597 (Mailing)
Johnson City, TN 37605-1597
(800) 456-9805
FAX (800) 999-5210

NRYS00110