



Company Confidential

# Hybrid Electric Heat Pump Water Heater

Product Overview

*05/06/2010*



# Presentation Agenda

- Heat Pump UNIT
  - Features & Benefits
  - Specifications
  - Operational Overview
  - Technology
- SELLING
  - Target Markets
  - Cost Justification
- SERVICE
  - Service/Warranty
- COMPETITION
  - Competitive Comparison
  - GE
  - Rheem
  - Steibel Eltron
  - Add-On Units
- VALUE PROPOSITION
- Questions??

# Hybrid Electric Heat Pump Water Heater – Elevator Speech

*“The Hybrid Electric Heat Pump water heater from American is the most versatile and energy efficient option for the homeowner looking to go **green** and save some **green** with the latest technology in electric water heating.”*

- 2.3 Energy Factor; Heat pump technology saves money...it’s more efficient to transfer heat (from air to water via compressor) than to create heat via resistance elements...so it uses less than half the electricity of comparably sized electric water heater
- Increased capacity vs. competitors
  - 80-gallon capacity takes advantage of heat pump capability to heat water economically by recovering slowly,
  - More Storage = More Savings
    - operates in maximum efficiency mode more often than 50-gallon models
      - » “Free” hot water versus using electric elements
  - National solution versus regional solution
    - Additional storage offsets performance restrictions in colder climates
  - **Energy Star qualified** to take advantage of 30% Federal tax credit, as well as regional and local utility incentives



**More Storage Equals More Savings !!!**

# Specifications

- **Primary Features & Benefits**

- 80-gallon capacity storage tank integrated with 850 watt compressor primary..... (60-gallon model due for release this summer)
- Compressor uses environmentally friendly R134a refrigerant, external coil heat exchanger wrapped around tank sealed w/ thermal paste
- Provides up to ½ ton cooling capacity and dehumidification as well
- Backup incoloy electric elements (2kw lower, 4.5kw upper)
- Maintenance-free powered anode protects tank from corrosion
- Removable plastic shroud provides component protection, service accessibility, directs airflow
- Consumer-friendly, washable, 12.4” x 16” filter installed in removable grille for easy cleaning
- 2” environmentally friendly, non-CFC foam insulation to reduce standby heat loss (*valued as R-16 insulation*)
- Safety features include factory-installed, side T&P valve set to 150 psi and brass, child-resistant drain valve
- 10 year limited warranty on tank/parts



# Specifications cont.

- **Operational Characteristics**

- Requires 240 VAC, single phase, 60 Hz power for compressor
- 4 Amp current for compressor
- Compressor ambient operating temperature; 45° to 109°
- Storage & transportation temperature; -40° to 165°
- Designed for residential applications, for indoor installation in a basement, garage or utility room
  - Attic installation not recommended
- Suggested 750 cubic feet of room space
  - Anything less requires louvered doors or other access to air
  - Future accessory ducting kits in development for release 2011



# Specifications cont.

- **Physical Characteristics**

- 82" high x 24" diameter
- Weight 314 lbs. empty, 967 lbs. full
- Water connections right side 3/4" NPT
  - cold inlet 4-1/4" from floor
  - hot outlet 55" from floor (PEX "j-tube" installed)
- User Interface Module ~65" height level
- Ships in wooden crate for fork lift trucks
  - crate dimensions 87" high, 29.5" wide, 29.5" deep; 410 lbs.
  - crate is "wrapped" with corrugated section containing important shipping information (carton banner, UPC, handling graphics, etc.)
- Unit is double bagged in plastic for protection

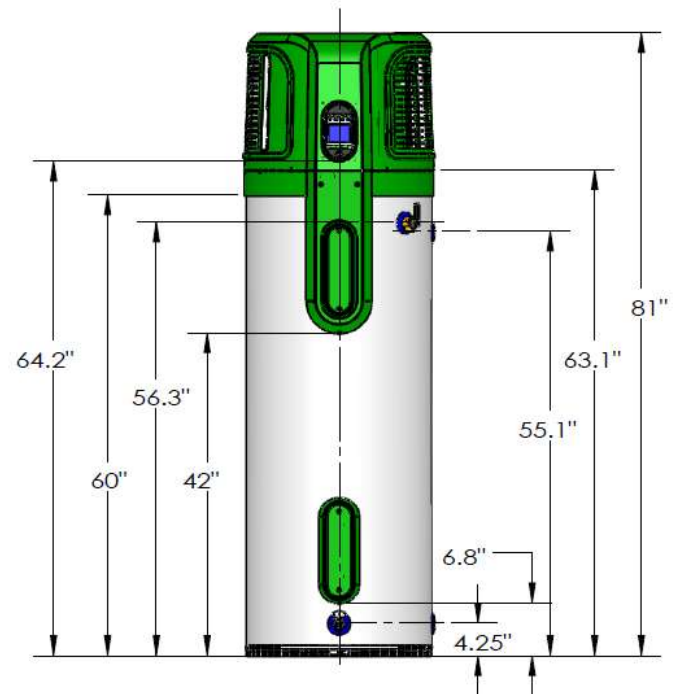

# System Performance

- **Performance Attributes**

- 2.3 EF, 70 gallon FHR in EFFICIENCY mode
- 2.3 EF, 84 gallon FHR in HYBRID mode
- .87 EF, 76 gallon FHR in CONVENTIONAL mode
- provides ½ ton “cooling capacity” when in efficiency mode
- maximum 150° F water temperature
  - use of tempering valve would allow higher set-point to effectively make hot water capacity last longer and allow compressor to efficiently heat water more slowly (vs. electric elements)
- Meets Uniform Plumbing Code 67 gallon FHR
- Already compliant with NAECA3





# User Interface Module

- Heads -up display of control & system status gives unit an “appliance look and feel” superior to competitive offerings
- Individual backlit mode buttons for selecting four operational modes:
  - Maximum Efficiency; utilizes the heat pump only to heat water unless outside ambient range
    - Will revert to elements if ambient temperature is outside safe operating range for heat pump
  - Hybrid; system utilizes heat pump and top element depending upon demand
  - Conventional Electric; system employs elements like a standard electric unit
  - Vacation; protects system components from freeze damage
- ‘High Tech” capacitive touch buttons
- Large LCD displays temperature in °F or °C
- Safety lock protects household from children changing set point
- Water temperature range; 95° to 150°
- Three-line display communicates current status and displays error messages if needed



# Design/Refrigerant Technology

- Technical Details
  - Coiled copper heat exchanger wrapped around tank, sealed with thermal paste for optimized heat exchange
  - Mitsubishi Rotary Compressor
  - Mammoth Evaporator
  - Condenser manufactured in-house
- R134a selected over alternatives because:
  - Environmentally friendly R134a refrigerant provides effective, safe heat exchange
  - R410a requires much higher operating pressures, which would have required more costly components, and lead to premature component/system failure

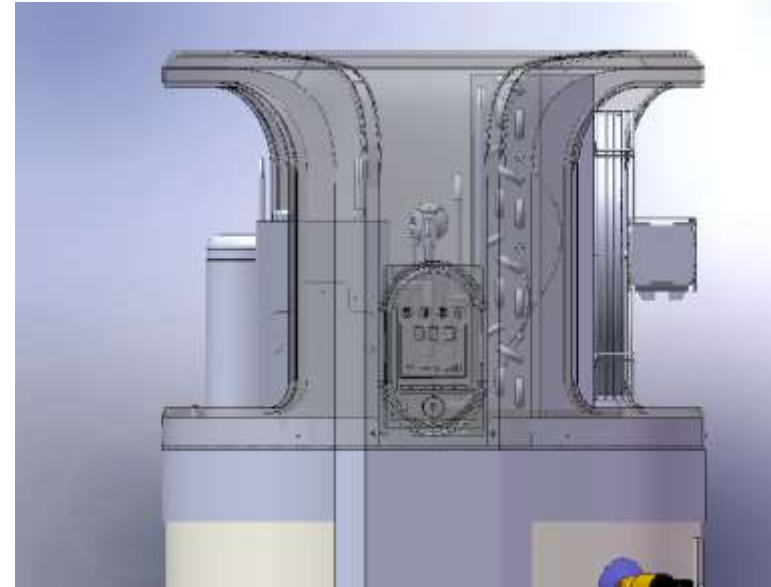

- SELLING

# Marketing Efforts/Focus

- Emphasis on Energy Star certification, and Federal tax credit have made the market more attractive – helps cost justify purchase
- Utility field trials will promote product and educate consumers regarding Hybrid Electric Heat Pump Water Heater – added benefit that utilities understand value of increased capacity
- Pitch as “green” product in market to contain/reduce energy costs
- Targeting early adopters and environmentally conscious, as well as cost conscious consumers, via significant savings in annual cost
- Geographic focus where heat pump capability is optimized – southern regions
  - Look for “sweet spots” where the cost of electricity makes the heat pump a more attractive solution
    - [http://www.eia.doe.gov/cneaf/electricity/epm/table5\\_6\\_a.html](http://www.eia.doe.gov/cneaf/electricity/epm/table5_6_a.html)
  - OUR solutions (80- and 60-gallon units) meet NAECA 3 regulations
  - Note compliance with UPC 67 gallon FHR



# More Storage Equals More Savings

- More storage equals more savings
  - More storage = more heat pump contribution
    - More heat pump = more free hot water
    - More free hot water = more savings

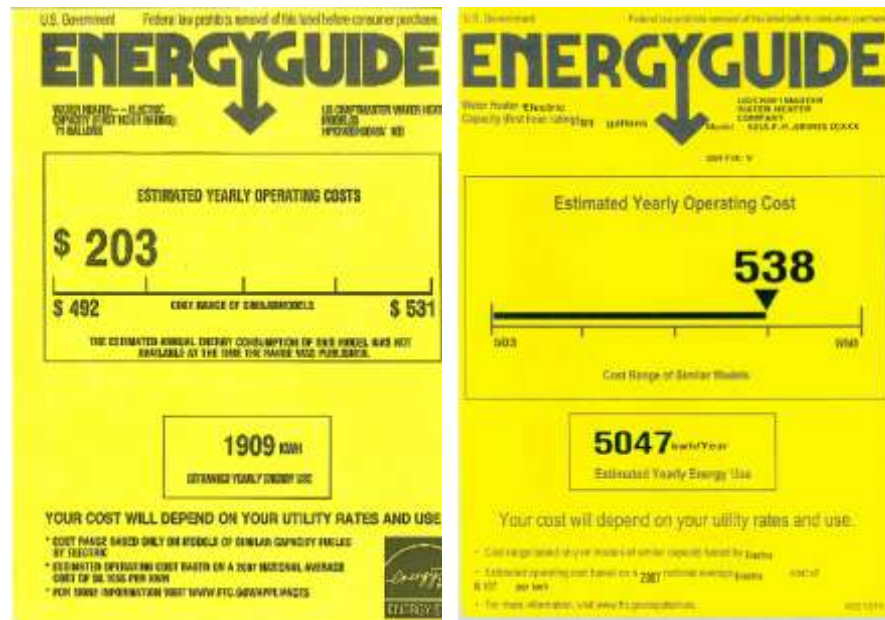

# Customer Strategy

- Key to selling is payback given Federal tax credit, local incentives, and cost savings
- Key to selling higher capacity is “more storage = more savings”
  - Reference that utilities prefer the larger capacity heat pumps in market
- Should be pitched as a “drop in replacement” for conventional electric, with exception that condensate draining is required, water connections are side vs. top (minor plumbing required), height difference, and space requirement\
- *Address size concerns with our 60-gallon model due to launch this summer*



# Customer Simplicity



- For customer simplicity, we have designed product to be as simple, reliable, and “turn-key” as possible
  - Washable filter
  - Powered anode, no maintenance
  - Shroud access to serviceable components
- User Interface is intuitive, consumer friendly; mode buttons, temperature adjustment and lock feature all simplified; competition requires detailed documentation to understand operation...
- If space is concern, make sure louvered doors are on room where unit is located; check heat exchange/air flow issues
- Remind consumer that the temperature delta input to output is ~5 to 9 degrees
- For concerns over unit size, note that our 60-gallon unit will be available soon!

# Regulatory Notes

- NAECA3 compliant...5 years before deadline
  - 60-gallon unit compliments portfolio of units >55 gallons
  - Competitors launching 40 gallon units to match their 50 gallon units ....why going smaller??
- UPC compliance for 3 bedroom, 3.5 bathroom homes with 67 gallon FHR (also compliant for 4 bedroom, 2.5 bathroom homes)
- Energy Star qualified
- Qualified for regional & local utility rebates
- Endorsed by key Utility players....



- SERVICE

# Service/Warranty

- 10 year limited warranty on tank and parts
  - Meets Energy Star criteria; match competition
- American will handle calls, on a brand-specific basis, via customer service call centers
- Service capability points:
  - Dry fire algorithm on startup
  - 3 line, 13 character display provides diagnostic reporting in easy to understand language
- System is designed for minimal component replacement for improved customer satisfaction and reliability
- Major service issue w/ unit will be resolved via unit replacement rather than on-site service of compressor components



# Service/Warranty

## REPAIR PART ILLUSTRATION

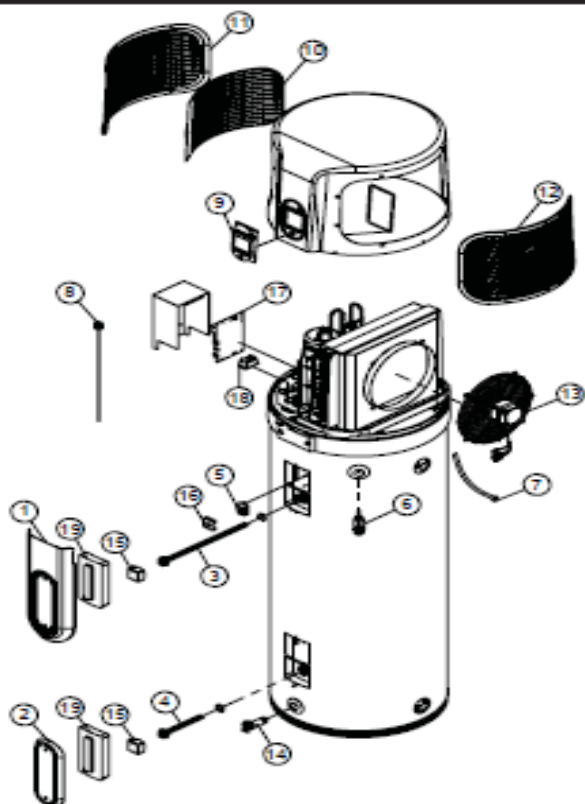

### REPAIR PARTS LIST

ITEM NO.	PARTS DESCRIPTION
1	Upper Access Cover
2	Lower Access Cover
3	Upper Element (4500 Watts)
4	Lower Element (2000 Watts)
5	Energy Cut-Off (ECO) Switch
6	Temperature & Pressure Relief Valve (T&P)
7	Dip Tube (at hot water outlet)
8	Powered Anode Rod
9	User Interface Module
10	Air Filter
11	Air Inlet Side Panel
12	Air Outlet Side Panel
13	Fan Assembly
14	Drain Valve
15	Protective Plastic Cover
16	ECO Cover
17	Control Board
18	Relay
19	EPS Cover
20*	Ambient / Coil / Discharge Temperature Sensor
21*	Upper / Lower Tank Temperature Sensor
22*	Run Capacitor
23*	Control Board Module Fuses

\* NOT SHOWN

### REPAIR PARTS

Repair parts may be ordered through your plumber, local distributor, home improvement center, or by calling 1-800-527-1953. When ordering repair parts always give the following information:

1. Model, serial and product number
2. Item number
3. Parts description

- COMPETITION

# HPWH – Control Competitive Comparison

	Appliance Look & Feel	Operating Mode Buttons	Temp. Display	Capacitive Touch Buttons	LCD Screen	Service or Error Code Displayed	Lockout Capability
American	yes	yes, 4	yes	yes	yes	yes, 3x13	yes
GE	not really	yes, 4	yes	no	yes	uncertain	yes
Rheem	not at all	yes, 3	no	no	none	none	none

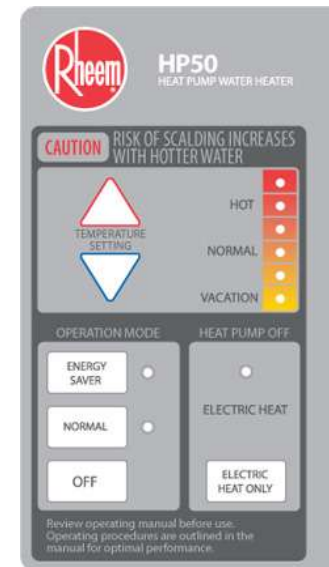

# 80 gal vs. 50 gal HPWH Actual Use

## American Provides More Hot Water

First Hour Ratings (in Hybrid Mode)

- GE 63 gallons
- Rheem 67 gallons
- American 84 gallons
  - *We meet UPC first hour in both Hybrid and Efficient modes!*

# 80 gal vs. 50 gal HPWH Actual Use

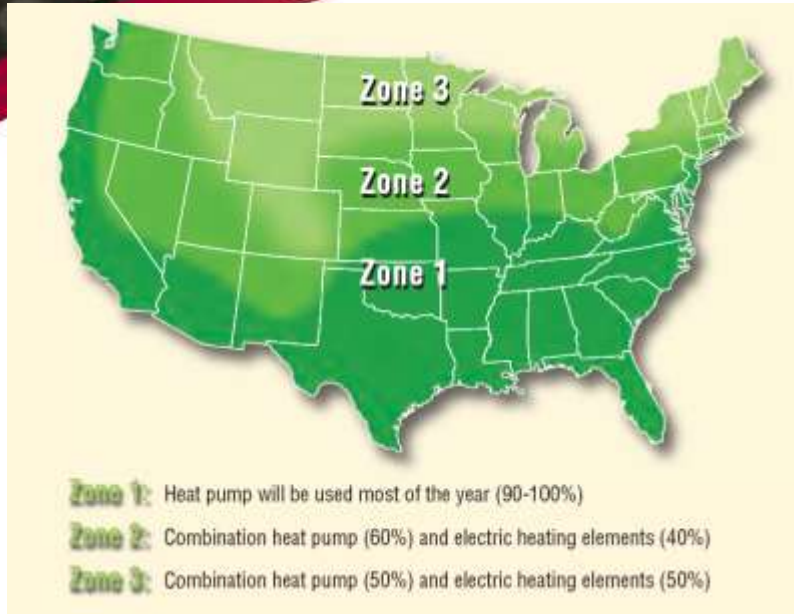

- 50 gal std electric = .91 EF
  - \$550 annual cost of operation
- Rheem/GE HPWH= 2.0 EF
  - \$248 HP mode\* annual cost of operation
- American HPWH = 2.3 EF
  - \$203 HP mode annual cost of operation

*\*GE unit 45 gallon capacity will limit ability to operate in HP mode*

	Rheem/GE		American		AWHC Advantage
	% HP	Annual Savings	% HP	Annual Savings	
Zone 1	0.8 - 0.9	\$242 - \$272	1.0	\$347	\$75 - \$105
Zone 2	0.6	\$181	0.8	\$278	\$96
Zone 3	0.5	\$151	0.7	\$243	\$92

# HPWH – Consumer Value Analysis

- Competitive pricing
  - Rheem consumer value \$1620  
(dropped at THD to \$1499)
  - GE consumer value \$1595  
(recently promoted in retail at \$1439)
  - Steibel Eltron consumer value \$3995!
  - **American consumer value \$1995**  
(suggested)
- Both Rheem & GE planning introduction of 40-gallon units...why???
- American 60-gallon unit available this summer



Save energy

GE

ENERGY STAR

**SPECIAL VALUE!**

now  
**\$1439** was **\$1599**

**50-Gallon GeoSpring Hybrid Water Heater**

- Consumes up to 62% less energy than standard electric water heater #79425

Available by Special Order in some markets.



# HPWH – Payback Competitive Comparison

Vendor	Model	MSRP (est.)	Tax Incentive Adjusted	Annual Operating Cost	Annual Savings vs. standard	Payback (Federal Tax Credit ONLY)
<b>AWHC</b>	<b>HPE10280H045DV</b>	\$ 1,995	\$ 1,397	\$ 203	\$ 347	2.3
comp. 1	50-gallon, EF 2.35*	\$ 1,500	\$ 1,050	\$ 198	\$ 352	2.1
comp. 2	50-gallon, EF 2.0	\$ 1,620	\$ 1,134	\$ 248	\$ 302	2.8

***Assumes water heated by heat pump mode only\****

Tax incentive = 30% Federal tax credit only

\* Assumption based upon DOE test protocol; actual use likely will have much higher cost for smaller capacity units since the elements will run more often

# HPWH – Competitive Points vs. GE

- Capacity
  - really only holds 45 gallons
  - Will operate on electric resistance elements more often than consumers will expect
- Filter removal requires additional 14 inches vertical clearance
- Operational complexity – modes not intuitive, some level of duplication
- Energy Guide is only \$5 lower than our 80-gallon unit; this reflects compliance with the DOE test rather than real life...GE will use the elements more often!



# HPWH – Competitive Points vs. Rheem

- Size – only holds 46 gallons
- Filter placement horizontally on top will result in catching debris and clogging
- R410a high pressure, limited temp range
- Circulating pump is single point of failure regardless of operational mode
- Primitive user interface
  - No ability to set precise temperature set point
  - No diagnostics/display
  - “cheap” design and cover



# HPWH – Competitive Points vs. Steibel Eltron

- Primitive operational characteristics
  - No temperature adjustment
  - No user interface
- High cost – unit sells for \$3500!!
- No aesthetics to look/feel – resembles our prototype units



Introducing the new Accelera® 300 heat pump water heater.

**Accelerate your savings !**

# HPWH – Competitive Points vs. add-on units

- Not Energy Star
- Not qualified for tax credits
- Anode rod depletion due to HEX...this voids our warranty due to accelerated anode rod depletion
- Cumbersome application
- Space consuming
- More components to fail



# Competitive Matrix - HANDOUT

## American Hybrid Electric Heat Pump Water Heater Advantages

Point by point



	American	GE	Rheem	ADVANTAGE
Listed Capacity	80 gallons	50 gallon	50 gallon	AWHC
Actual Capacity	78 gallons	45 gallons (unable to take optimal advantage of conditions having plentiful ambient heat)	46 gallons (unable to take optimal advantage of conditions having ambient plentiful heat)	AWHC
First Hour Delivery (In Most Efficient Mode)	70 gallons (DEFAULT mode)	Published 50 gallons; AWHC test yielded 38 gallon FHR	Published 67 gallon; AWHC testing yielded 52 gallon FHR	AWHC
First Hour (in Hybrid Mode)	84 gallons	Published 63 gallons; AWHC test yielded 61 gallon FHR including significant element contribution (DEFAULT mode)	Published 72 gallons; AWHC test yielded 57 gallon FHR including significant element contribution (DEFAULT mode)	AWHC
Annual Cost of Operation (DOE ENERGY GUIDE Test)	\$203	\$198	\$234	real-world usage - AWHC
Reliability	Coil around tank with thermal paste; compressor adequately sized to extract heat even in marginal geographies	Coil around tank (like AWHC) with smaller compressor - unable to take optimal advantage of marginal conditions	Circulating loop external heat exchange; high pressure R410a refrigerant restricts compressor operating range, circulating pump is constant power draw & potential single point of failure (regardless of operating mode); external plate heat exchanger subject to scale buildup	AWHC & GE
Operating Modes	Four modes; <b>Efficient</b> takes advantage of compressor, <b>Hybrid</b> enables quicker recovery from long draws with economic advantage of compressor, <b>Conventional</b> suspends compressor in temporary seasonal conditions of low heat availability, <b>Vacation</b> protects system from freeze damage while not in use.	Five modes; eHeat employs compressor, Hybrid and High Demand nearly identical with different recovery algorithms (High Demand utilizes elements longer), GE User's Manual mode explanation difficult to understand & confusing, otherwise functions similarly to AWHC solution. (NOTE: HYBRID is default mode.)	Three modes; <b>Energy Saver</b> has limitations operating heat pump (won't activate unless temp is between 80 & 110), <b>Normal</b> is hybrid default mode, <b>Electric Heat Only</b> mode utilizes both elements.	AWHC
Electronic Controls	User-friendly touch pad with LCD 3 line x 13 character display provides ease of use & communicates information in clear easily understandable manner.	User-friendly LCD with membrane touch switches for mode selection, provide ease of use & adequate operational information.	User interface with basic controls (no specific temperature indication, no digital display, no diagnostics) for modes and temperature setpoint via various "ranges".	AWHC
Water Temperature Range	Set point range from 95 to 150; adequate for consumer needs and provides ample hot water storage when ambient heat is available (could equate to more hot water when higher setpoint is utilized with mixing valve)	Set point range from 100 to 140; provides less hot water storage capability & reduced ability to economically extract and store heat.	Set point range from 90 to 140; provides less hot water storage capability & reduced ability to economically extract & store heat. (NOTE: unit cannot utilize compressor to heat incoming water less than 80 degrees due to R410a refrigerant, compromising heat pump efficiency.)	AWHC
Anode	Powered anode rod - no need to replace, no maintenance required.	Conventional anode; not easily accessible through compressor components, requires replacement or anode will deplete & tank will corrode.	Conventional anode; not easily accessible through compressor components, requires replacement or anode will deplete & tank will corrode.	AWHC
Filter Accessibility	Washable, horizontally side mounted for easy access.	Washable, vertically top-mounted, requires 14" height above unit for removal making unit effective height 77".	Washable, horizontally top-mounted, may be difficult to access via top, will be subject to falling debris & dust.	AWHC
Backup Element(s)	Two backup elements, 2KW & 4.5KW incoloy.	Two backup elements, 4.5KW each.	Two backup elements, 2KW each, stainless steel, can run simultaneously.	AWHC & GE
Grid Management Capability	Yes, 10-pin connector side-mounted & easily accessible.	Yes, RJ45 connector side-mounted & easily accessible.	No, not grid management capable.	AWHC & GE

AWHC Confidential - for internal use only

- VALUE PROPOSITION

# Hybrid Electric Heat Pump Value Proposition

- Green theme on saving money
  - Energy Star qualified to take advantage of 30% Federal tax credit, as well as any local utility incentives
- Savings - uses approximately half the electricity of a comparably sized electric water heater, and provides up to ½ ton cooling capacity and dehumidification as well
- Payback within 3 years, highlight financial incentives and websites to promote
- Increased capacity
  - 80-gallon capacity enables the unit to operate in the maximum efficiency mode more often than other models having lower capacity, takes optimal advantage of the heat pump capability to heat water for large families or those having higher than normal hot water requirements

